

LT20JE

Telescopic Boom Lifts-Electric



Safe and Reliable

- High quality tilt and weight sensor, for safe and reliable operation;
- Modern electronic control system to provide security and safety;
- The protection level of components of the whole machine is above IP65

Intelligent and efficient

- The turntable rotation 360° continuously with compact tail, suitable for narrow space operation
- Combine calibration with intelligent and efficient system;
- Oscillating axles as standard;
- Four wheel strong AC electric drive, climbing capacity up to 45%, strong trafficability;
- High-power charger, large-capacity power battery, fast charging, ultra-long endurance.

Energy saving and comfort

- Smooth descent on all booms;
- Automatic deceleration at the action limit position, stable action, proportionate control;
- ECU control ensures optimize battery usage.

Green and environmental protection

- Pure electric power, low use and maintenance cost, high return on investment;
- Green and environmental protection, no emission, low noise, meet indoor and outdoor working conditions.

Standard configuration

- Platform work lights
- Working strobe lamp
- Load Sensing System
- Electro hydraulic proportional control
- Automatic brake system
- Tilt protection system
- Telematics-BOX
- Electric emergency descent system
- Manual emergency descent system
- Emergency stop system
- Anti entrapment device
- Remote fault diagnosis system
- Overload protection
- Efficient alarm warnings



LT20JE >>>



Main Parameters

Item	Unit	LT20JE
Size		
Max.Working Height	m	21.5
Max.Platform Height	m	19.5
Max.Operating Range	m	14
A-Overall Length (Stowed)	m	10.2
B-Overall Width (Stowed)	m	2.42
C-Overall Height (Stowed)	m	2.75
Overall Length (Transport)	m	10.2
Overall Width (Transport)	m	2.29
Overall Height (Transport)	m	2.67
Platform Size (L×W×H)	m	1.83 × 0.76 × 1.1
Turntable Tailswing (Stowed/Raised)	m	1.95/1.55
D-Ground clearance	m	0.31
E-Wheelbase	m	2.5
Turning Radius (Inside/Outside)	m	2.4 / 5.5
Tyres	/	33×12-20 (Solid off-road tyre)
Performance		
Platform Load (Unrestricted)	kg	320
Max. Platform Occupants	/	2
Gradeability	/	45%
Travel Speed (Stowed)	km/h	5
Travel Speed (Raised)	km/h	1
Max.Working Slope	/	X-5° / Y-5°
Turret Rotation	/	360° Continuous
Platform Rotation	/	±90°
Jib Movement	/	-65° ~ +70°
Drive Steering Type	/	4 WD × 2 WS
Weight		
Overall Weight	kg	9,500
Power		
Battery (Lithium)	/	48 V / 460 Ah
Charger	/	48 V / 60 A
Driving Motor	/	32 VAC / 3.3 kW
Lifting Motor	/	31 VAC / 10 kW
Hydraulic Tank	L	93

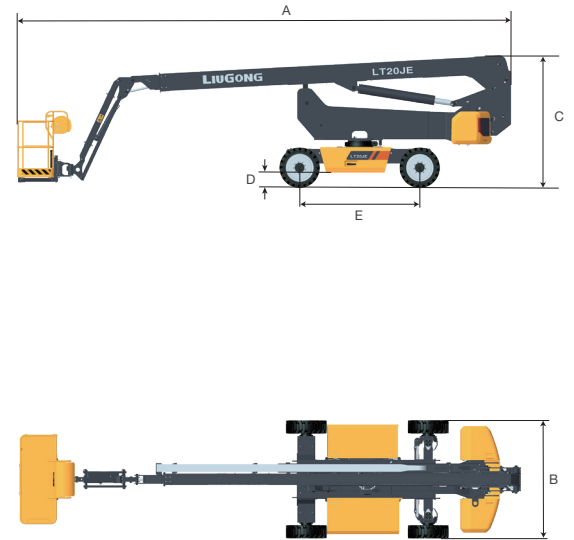

Unit: m

LT20JE Performance Curve

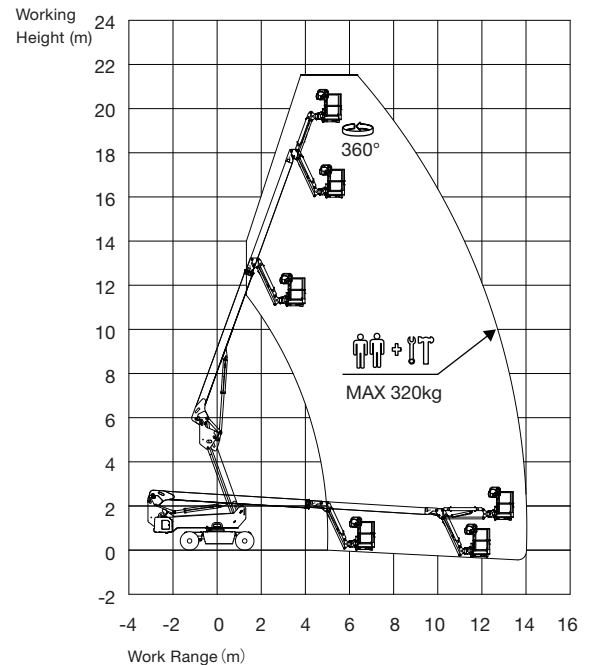

LA20JE

Articulating Boom Lifts-Electric



Safe and Reliable

- High quality tilt and weight sensor, for safe and reliable operation;
- Modern electronic control system to provide security and safety;
- The protection level of components of the whole machine is above IP65

Intelligent and efficient

- The turntable rotation 360° continuously with compact tail, suitable for narrow space operation
- Combine calibration with intelligent and efficient system;
- Oscillating axles as standard;
- Four wheel strong AC electric drive, climbing capacity up to 45%, strong trafficability;
- High-power charger, large-capacity power battery, fast charging, ultra-long endurance.

Energy saving and comfort

- Smooth descent on all booms;
- Automatic deceleration at the action limit position, stable action, proportionate control;
- ECU control ensures optimize battery usage.

Green and environmental protection

- Pure electric power, low use and maintenance cost, high return on investment;
- Green and environmental protection, no emission, low noise, meet indoor and outdoor working conditions.

Standard configuration

- Platform work lights
- Working strobe lamp
- Load Sensing System
- Electro hydraulic proportional control
- Automatic brake system
- Tilt protection system
- Telematics-BOX
- Electric emergency descent system
- Manual emergency descent system
- Emergency stop system
- Anti entrapment device
- Remote fault diagnosis system
- Overload protection
- Efficient alarm warnings



LA20JE >>>



Main Parameters

Item	Unit	LA20JE
Size		
Max.Working Height	m	22.2
Max.Platform Height	m	20.2
Max.Operating Range	m	13.2
A-Overall Length (Stowed)	m	8.87
B-Overall Width (Stowed)	m	2.42
C-Overall Height (Stowed)	m	2.32
Overall Length (Transport)	m	8.87
Overall Width (Transport)	m	2.29
Overall Height (Transport)	m	2.2
Platform Size (L×W×H)	m	1.8 × 0.76 × 1.1
Turntable Tailswing	m	0.72
D-Ground clearance	m	0.31
E-Wheelbase	m	2.5
Turning Radius (Inside/Outside)	m	2.4 / 5.5
Tyres	/	33 × 12 - 20 (Solid off-road tyre)
Maximum crossing height	m	8.3
Performance		
Platform Load (Unrestricted)	kg	260
Max. Platform Occupants	/	2
Gradeability	/	45%
Travel Speed (Stowed)	km/h	5
Travel Speed (Raised)	km/h	0.6
Max.Working Slope	/	X-5° / Y-5°
Turret Rotation	/	360° Continuous
Platform Rotation	/	±90°
Jib Movement	/	-65° ~ +70°
Drive Steering Type	/	4 WD × 2 WS
Weight		
Overall Weight	kg	9,500
Power		
Battery (Lithium)	/	48 V / 460 Ah
Charger	/	48 V / 60 A
Driving Motor	/	32 VAC / 3.3 kW
Lifting Motor	/	32 VAC / 10 kW
Hydraulic Tank	L	93

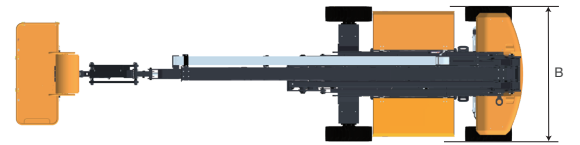
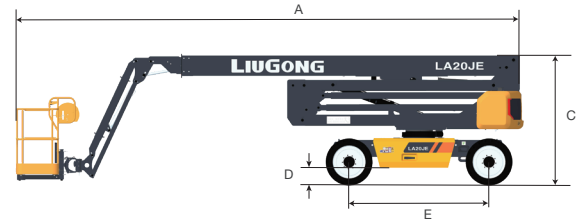

Unit: m

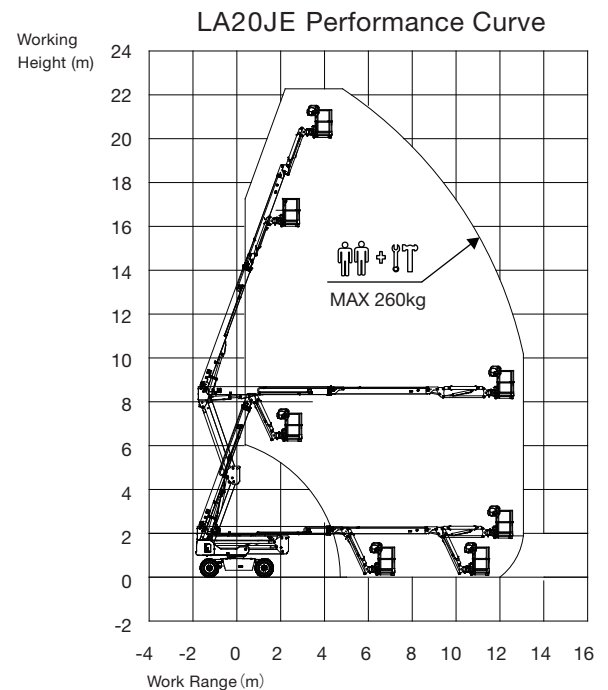

LT26JE

Telescopic Boom Lifts-Electric



Safe and Reliable

- High quality tilt and weight sensor, for safe and reliable operation;
- Modern electronic control system to provide security and safety;
- The protection level of components of the whole machine is above IP65

Intelligent and efficient

- The turntable rotation 360° continuously with compact tail, suitable for narrow space operation
- Combine calibration with intelligent and efficient system;
- Oscillating axles as standard;
- Four wheel strong AC electric drive, climbing capacity up to 45%, strong trafficability;
- High-power charger, large-capacity power battery, fast charging, ultra-long endurance.

Energy saving and comfort

- Smooth descent on all booms;
- Automatic deceleration at the action limit position, stable action, proportionate control;
- ECU control ensures optimize battery usage.

Green and environmental protection

- Pure electric power, low use and maintenance cost, high return on investment;
- Green and environmental protection, no emission, low noise, meet indoor and outdoor working conditions.

Standard configuration

- Platform work lights
- Working strobe lamp
- Load Sensing System
- Electro hydraulic proportional control
- Automatic brake system
- Tilt protection system
- Telematics-BOX
- Electric emergency descent system
- Manual emergency descent system
- Emergency stop system
- Anti entrapment device
- Remote fault diagnosis system
- Overload protection
- Efficient alarm warnings



Liugong Machinery Europe B.V.
P.J. Oudweg 4
1314 CH Almere
The Netherlands
Mail: info@liugong-europe.com

www.liugong-europe.com

We reserve the right to change the plan and parameters without informing the users as Liugong products are constantly updated and improved.

The product configuration and appearance in the photo are different from the actual model which should be subject to the actual product.

Liugong series logo in this brochure is a registered trademark of Guangxi Liugong Group Company, which has been legally authorized to use by us. Others are not allowed to use it without authorization.

LT26JE >>>



Main Parameters

Item	Unit	LT26JE
Size		
Max.Working Height	m	28.1
Max.Platform Height	m	26.1
Max.Operating Range	m	19.88
A-Overall Length (Stowed)	m	11.03
B-Overall Width (Stowed)	m	2.44
C-Overall Height (Stowed)	m	2.88
Overall Length (Transport)	m	11.31
Overall Width (Transport)	m	2.28
Overall Height (Transport)	m	2.68
Platform Size (L×W×H)	m	2.4 × 0.9 × 1.1
Turntable Tailswing (Stowed/Raised)	m	2.6/1.6
D-Ground clearance	m	0.3
E-Wheelbase	m	3
Turning Radius (Inside/Outside)	m	3.5 / 6.8
Tyres	/	385 / 65 - 24 (Solid off-road tyre)

Performance

Platform Load (Unrestricted)	kg	300 / 454
Max. Platform Occupants	/	2
Gradeability	/	45%
Travel Speed (Stowed)	km/h	5
Travel Speed (Raised)	km/h	1
Max.Working Slope	/	X-5° / Y-5°
Turret Rotation	/	360° Continuous
Platform Rotation	/	±90°
Jib Movement	/	-65° ~ +70°
Drive Steering Type	/	4 WD × 2 WS

Weight

Overall Weight	kg	15,000
----------------	----	--------

Power

Battery (Lithium)	/	83.2 V / 460 Ah
Charger	/	80 V / 80 A
Driving Motor	/	52 VAC / 5.2 kW
Lifting Motor	/	52 VAC / 30 kW
Hydraulic Tank	L	140

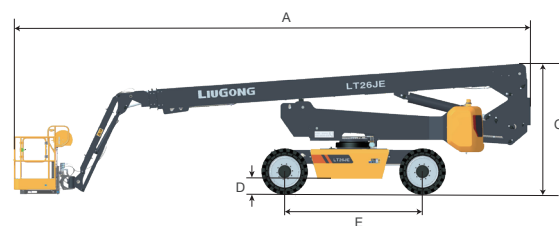

Unit: m

LT26JE Performance Curve

